

Installation of Denfit StreetWorkout in soft surface

Before starting with the installation, check if all the parts on the drawing are delivered.

The Street Workout units are installed on separate foundation frames that are placed 750 mm into the ground. There are two types: $\varnothing 230$ for the 100x100 posts and $\varnothing 115$ for round posts (Parallel Bars, Dumbbell post, etc).

$\varnothing 230$ frames

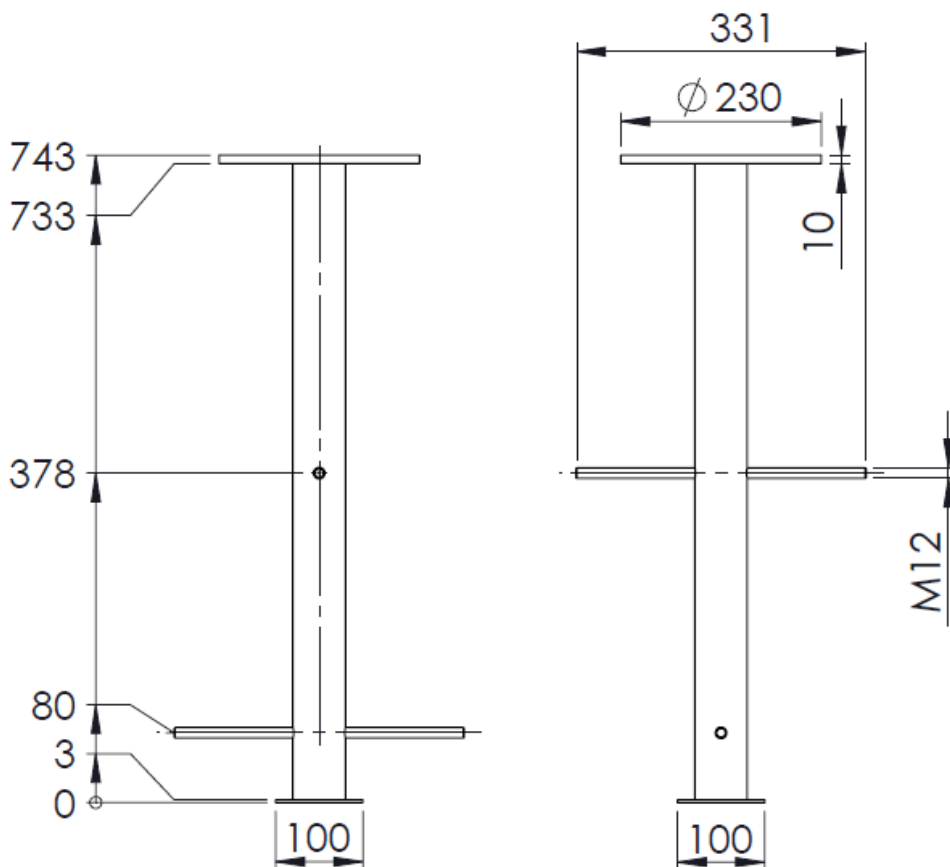

Ø 115 frames

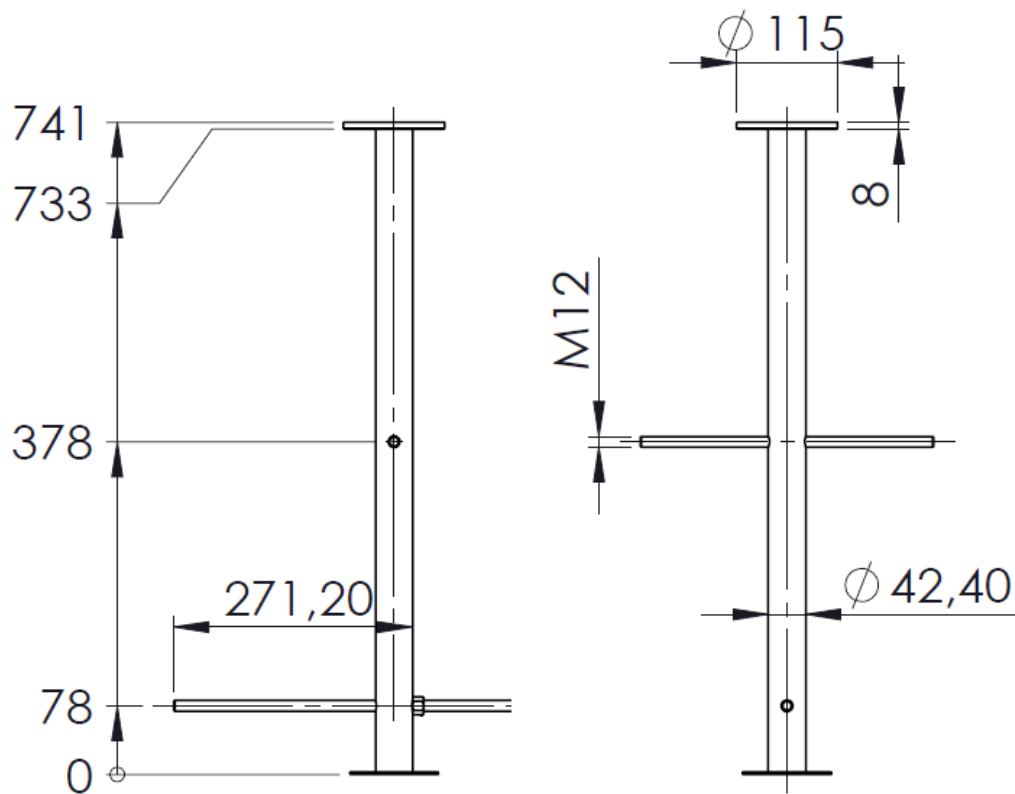

1 – Dig holes with a depth of 750 mm. For most types of soil the dimensions of the hole should be 500x500x750mm.

When the soil is very loose (like sand) a bigger hole is advised.



2 – Attach the frames to the posts, first by hand and finish with a drill.



Only use a drill to completely tighten the bolt, be careful not to damage the coating.



3 – Put the threaded rods through the frame and put the frame in the hole.



4 – Connect all the bars and the ridges:





When the bar is installed between the posts screw in the security bolt halfway **by hand. Do not use a drill.**

Then do the adjustments and make sure that the posts are completely level and straight.

Should a bar not go over a ridge smoothly, you can use WD40 to help it.



Use a level:



You can use straps to support the frame:



5 - Add fast-setting concrete into the hole. It depends on the condition of the soil and the size of the hole how much this should be. For most types of soil the dimensions of the hole should be 500x500x750mm; this gives around 0.12 m³ of concrete. When the soil is very loose (like sand) a bigger hole and more concrete is advised.

The concrete should NEVER be less than 200mm below ground level! There should always be at least 200mm of loose fill on top of the concrete.



6 - Tighten the security bolts completely **ONLY** when the posts are level, **use Loctite:**



7 - Then close the hole with sand/soil. Use a compacting machine to press the soil together. The soil should be packed tightly.



To ensure the correct bar height, dry sand or loose filling (fall protection like bark mulch, artificial grass, woodchip, gravel, wet pour/Playtop/EPDM, etc.) must be applied up to the surface level (= footplate of the post).



BEFORE APPLYING WET POUR, GRAVEL, ARTIFICIAL GRASS, ETC. MAKE SURE THAT THE COMPLETE UNIT IS LEVEL, STABLE AND CORRECTLY INSTALLED! AND CHECK IF THE PRODUCT FUNCTIONS AS IT SHOULD.

Ground prepared to add wet pour/Play top/EPDM:



Finished result with EPDM:



Ground prepared for rubber tiles:



Finished result with rubber tiles:

